

# Air & Water Advanced DHW

## Domestic Hot Water



An energy efficient kit provides multi zone ducted climate control and domestic hot water heating, all cleverly powered by just one heat pump.

### OVERVIEW

Air & Water Advanced DHW provides a low-cost means of providing multi zone air heating or cooling in your home, as well as hot water heating in your home.

The difference with Ata Touch: It uses the same heat pump to both heat or cool the air and heat your hot water.

This minimises your capital outlay whilst maximising your return on investment through significant energy savings.



### FEATURES

- Multi zone ducted with damper controlled air flow (1 to 6 zones).
- Heats water up to twice as fast as an electric element or gas.
- Uses electricity – in NZ a predominantly renewable energy – a great choice for the environment.
- Optimises water heating based on your use and ensures hot water when you need it.
- Legionnaires protection – heating water weekly to above 60°C for 60 minutes.
- Optional event scheduling to better manage your energy use.
- Powered by one of the most trusted heat pump manufacturers, Fujitsu, with its split ducted series.
- Whisper quiet, units operate as low as 25 to 29 decibels.

### FUNCTIONS

The Air & Water Advanced DHW kit determines whether water is being heated or whether your room requires heating or cooling. Ata Touch also better manages the process to create greater efficiencies by directly controlling the temperature set point more accurately.

Air & Water Advanced DHW can run either stand alone or integrated with the Ata Touch automation system.

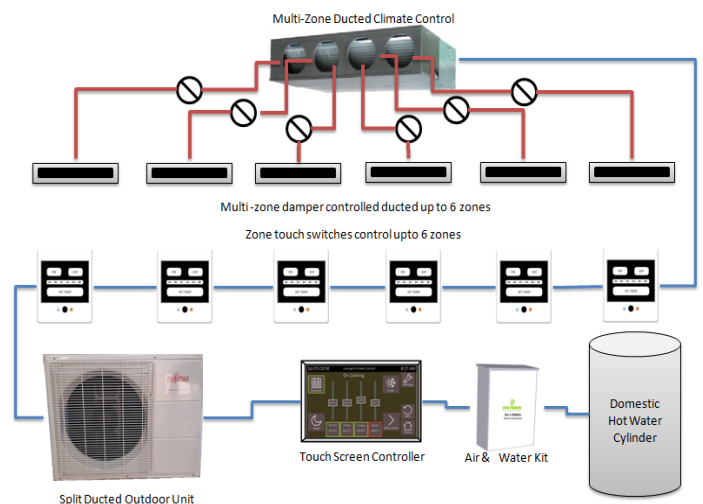

## Ata Touch Air & Water Advanced DHW

<b>Electrical</b>	Power Supply		1, 230, 6, 50	Ø, V, A, HZ
	Electric Element (max)	Switched	3	KW
<b>Performance</b>	Nominal Capacity	Heating	6.0 to 10.3	KW
	Water Temperature Range	Heating	15 to 54	°C
<b>Water</b>	Pipe Size	In - Out	20 (3/4) BSP	mm (inch)
	Distance to Cylinder (Max)		15	m
	Water Pump (max pressure)	3 speed	1.1, 1.9, 3.2	m <sup>3</sup> /h
	Head Height (max)		1, 4, 7	m
<b>Sound</b>	Sound Pressure	Heating	5	dB(A)
<b>Operating Range</b>	Ambient (Air to Water)	Heating	-20 to 32	°C
<b>Dimensions</b>	Weight		18	kg
	Dimensions (WxHxD)		310 x 450 x 230	mm
<b>Refrigeration</b>	Powered by	Fujitsu Split Ducted SET-ARTG30LHTDP to SET-ARTG54LHTDP		
	Refrigerant	Type	R410A	
	Pipe Size (outdoor to A&W)	Liquid	9.52 (3/8)	mm (inch)
		Gas	15.875 (5/8)	mm (inch)
	Pipe Size (A&W to Ducted)	Liquid	9.52 (3/8)	mm (inch)
		Gas	15.875 (5/8)	mm (inch)
	Installation restrictions	Max Length	50 to 75	m
		Max Height	20 to 30	m
Min Length		5	m	
	COP (ave 16 to 54°C)	Heating	3.7	W/W
<b>Ducted Air</b>	No. Zones		1 to 10	

## Ata Touch – Energy Efficient Smart Home - Solution

HEAT PUMP	SECURITY	FEATURES	LIGHTING	DEVICE CONTROL
Hi-Wall split Ducted zone controlled Domestic hot water Spa pool Swimming pool Underfloor heating	Intrusion detection Smoke detection Monitored	Away shutdown mode Scheduling Realtime clock Photo frame Smart device app Graphical configuration Diagnostics	Mood lighting Night motion lighting Smart device lighting General lighting Feature lighting Garden lighting Outdoor lighting Path lighting	Extractor fan Blind Curtain Gas fire Window Gates Garage Doors Doors Water systems

Air & Water Essential DHW is part of a holistic Energy Efficient Smart home system known as Ata Touch.  
For more information

**Contact Ata Touch [sales@atatouch.co.nz](mailto:sales@atatouch.co.nz) to find out more about how to best control your home**